

Instruction for 1000W DC/DC Converter



1. Overview

1000W DC-DC Converter, Hangzhou Tiecheng, can install in electric vehicle, supplying 12V/24V power to low voltage application in vehicle. Output terminal can connect directly to 12V/24V back-up battery pack. DC-DC Converter will management the charging process of back-up battery automatically. Fully sealed potting can be highly waterproof and dust proof, highly temperature resistance, highly vibration resistance.

The diagram between DC-DC Converter, 12V/24V back-up battery pack, low voltage

equipment and BMS is as below.

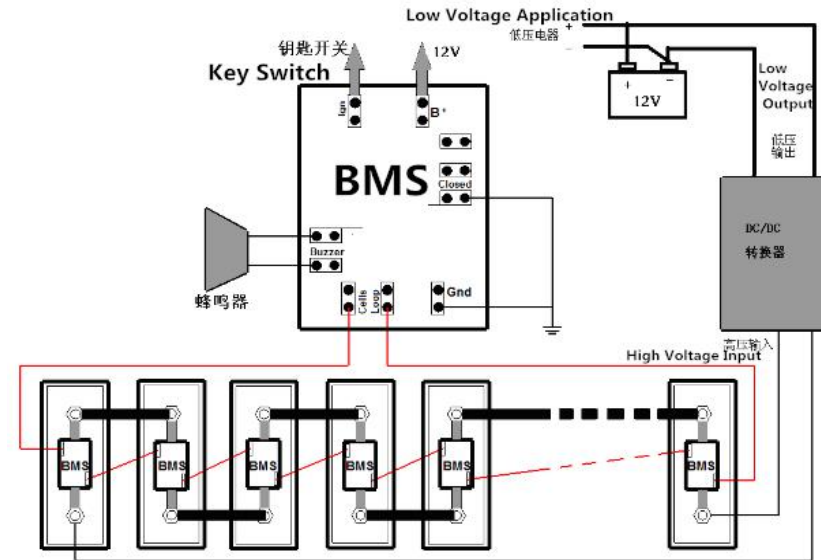

2. Basic Function

- 2.1 Transfer high voltage from power battery into low voltage of 12V/24V
- 2.2 Management charging process of 12V/24V back-up battery
- 2.3 Enable control through input high voltage or 12V/24V.
- 2.4 Protection function including low voltage input protection, reverse protection, output short circuit protection, over heating protection etc.,.
- 2.5 Fully sealed waterproof potting, no fan, nature cooling.

3. Technical Specification

3.1 Product name

3.1.1 Model Name

3.1.2 Model name method

Item	Description
Output Voltage	12=13.8V, 24=27.6V
Input Voltage	72=72V, 96=96V, 144=144V
Power	A=50W, B=100W, C=200W, D=300W, E=400W, F=500W,

G=600W, H=800W, I=1000W, J=1500W, K=2000W
--

3.1.3 Configuration No. Name

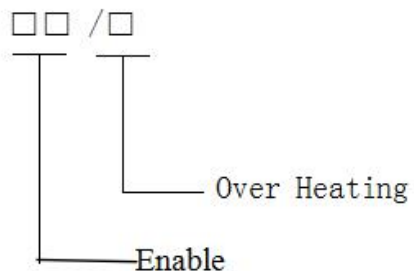

3.1.4 Configuration No. Name Way

Item	Description
Enable	AF=No Enable, AH=12V/24V Enable Control
Cooling	F--With Fan, N--Nature Cooling, W--Water Cooling, M--Module

3.2 Model List

Nominal Input	Nominal Output	Model	Note
72V	13.8V	TDC-I-72-12	
	27.6V	TDC-I-72-24	
96V	13.8V	TDC-I-96-12	
	27.6V	TDC-I-96-24	
144V	13.8V	TDC-I-144-12	
	27.6V	TDC-I-144-24	

3.3 LiFePO4 Battery Model Option(Other Lithium Battery suitable)

Model	Nominal Voltage of Single Cell/Max Voltage	Battery NO in Series	Max Input Voltage

TDC-I-72	3.2/3.6V	18-27Cells	100V DC
TDC-I-96		24-36Cells	133V DC
TDC-I-144		38-54Cells	200V DC

3.4 Features

		72-12	72-24	96-12	96-24	144-12	144-
input	Nominal Voltage	DC72V		DC96V		DC144V	
	Nominal Current	14A		10.5A		7A	
	Input Voltage	50-100V		64-133V		100-200V	
	Protection Point of	50V±2%		64V±2%		100V±2%	
	Protection Point of	100V±2%		133V±2%		208V±2%	
	Max Input Voltage	≤100V		≤150V		≤250V	
	Inrush Starting	≤15A					
Output	Nominal Voltage	13.8V±1% @ 12V					
	Output Voltage	27.6V±1% @ 24V					
	Nominal Current	70A±5% @ 12V					
	Output Current	40A±5% @ 24V					
	Nominal DC	1000W					
	Max Efficiency	≥92%					
	Output Voltage	≤50ms					
	Voltage	0.5%					
	Load Regulation	≤1%					
	Steady Voltage	≤1%					
	Steady Current	≤5%					
	Current Leaking of	2.2mA±1mA					
	Output Ripple	≤500mV					
	Output Over	16V±1V@12V Output, 32V±1V@24VOutput					
12/24V Enable	≤10mA						
Requirement of	16mm2 @ 12V 10mm2 @ 24V						

	Requirement of	0.5 mm ² —0.75mm ²
Other	Working	—30~60 °C
	Storage	—45~105°C
	Moisture of	5%~95%Non-condensing
	Protection Level	GB4208-2008 IP66
	Voltage	Input 2000V DC to shell, there is no
	Insulation	In the environment of (23±2) °C and moisture at
	Noisy	Distance in 1.5m, Noisy≤50dB
	Electromagnetic	DC / DC electromagnetic compatibility meet
	Reliability	MTBF 150000 H

3.5 Efficiency Curve

3.5.196V TO 12V Efficiency Curve

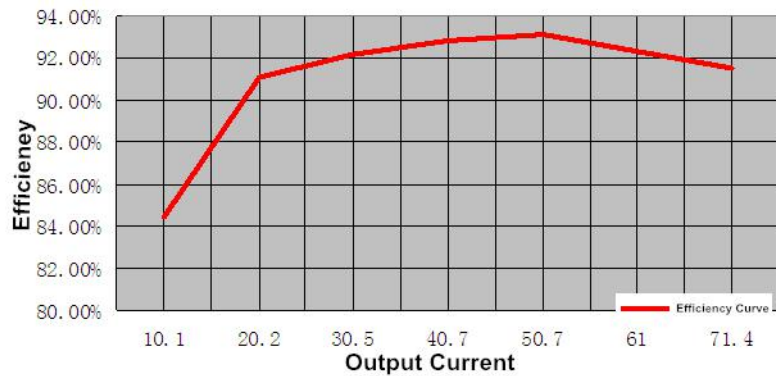

3.52 144V TO 12V Efficiency Curve

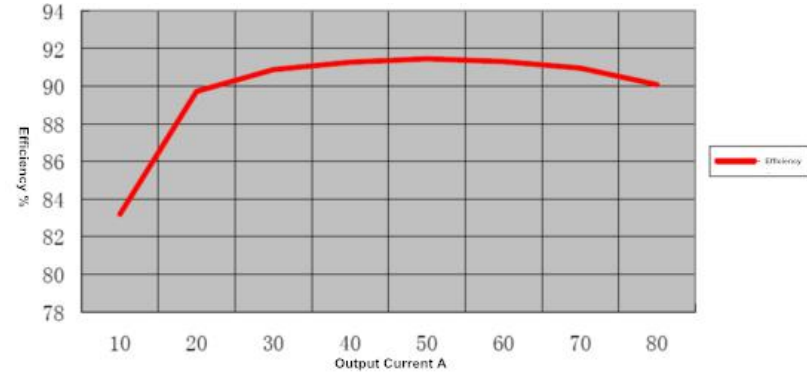

3.6 Interface Definition design

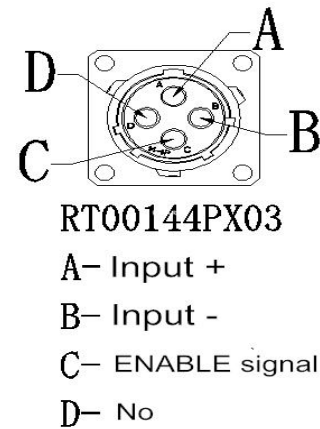

3.7 Resisting Voltage Functional

Terminal to ground (shell) and dielectric strength between each other without electricity connection circuit, should be tolerated test voltage as shown in the table below, there should not be a corona test between terminal, ionization, flashover or breakdown phenomenon.

Diagram 1 Test Voltage

The input to the shell	2000V DC	1min	Leak Current≤1mA
The input to the output	-	-	-

The out put to the shell	-	-	-
--------------------------	---	---	---

1. Protection Features

Input under-voltage Protection	When input lower than the protection point will be stopped work. Higher will be extended 2 seconds automatically resume. Know the protection point from <Product Technical Specification Form>
Input over-voltage protection	Will be Cut down when input over-voltage and less of protection level restarting in 2 seconds.. Know the protection joint from <Product Technical Specification Form>
a) Input reverse protection	refuses to start when input reverse . It can avoid any destroy.
b) Output over-Current limit	Output current is larger than 70 a, constant rise no longer current and voltage drop. Automatic recovery.
Output Short-Circuit protection	When Output short circuit, the detected voltage below 6V. The current will be fell to one of third rate. But, no damaged and recovery automatically.
Over-heat protection	When the Shell temperature over 80 degrees, the output Power starting fell down, Shut down when it arrived 90 degrees. Automatically resume working with the voltage is normal again.

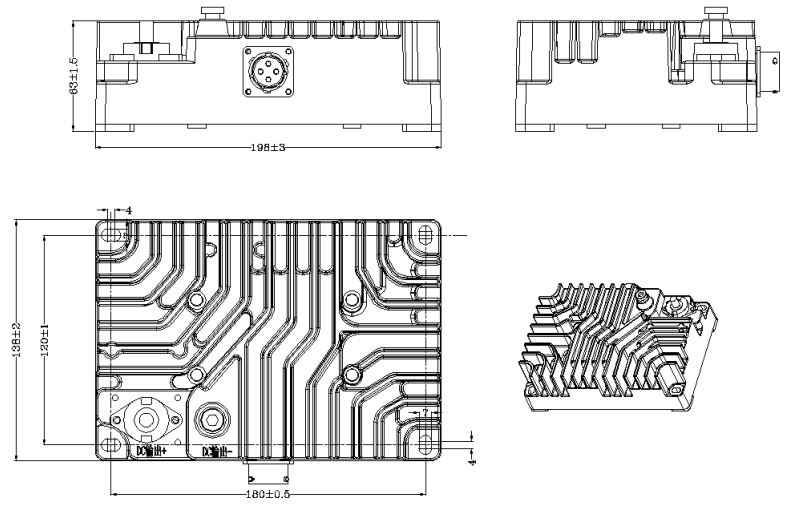

5. Label Format (For example TDC-I-144-12)

6 .Installation Size (Unit: mm)